



NOZZLE TECHNOLOGIES FOR IRON AND STEEL FOUNDRIES

Author: Rudi Bittniok

This article will give you an overview of actual nozzle technologies for iron autopour and steel bottom pour applications.

Looking at steel foundries in particular, lip pouring by Teapot ladles or when using bottom pour technologies, a one shot, low alumina nozzle are widespread technologies. Over the years, new long life or quick change solutions have been developed.

Cross-Bore and Multi Life nozzle solutions have been mentioned in previous articles (see below). We now also introduce our new VAPEX FosFlow nozzle system. Finally we include our newly developed Zirconia nozzles, which are used for the production of metal powders for additive manufacturing using 3D printers to create complex steel structures.



ONE SHOT NOZZLE APPLICATIONS

Those pressed nozzles (Figure 2) containing 38 % with or without 5% of Graphite or up to 80% alumina (no C) are mainly used as one shot application using a well block in a bottom pour ladle.

After the ladle is empty and the slag is removed, the nozzle is change manually which is not an easy job to do, especially when the ladle doesn't has a well block.

We also recommend a L0 – L3 well block (Figure 1) when using standard nozzle 1A – 3A shape.

FOSECO can supply one shot nozzle systems out of their brand names VISO (Isopressed) and VAPEX (extruded).

The FOSECO range contains many pressed and cast nozzles but also different kind of nozzles that can be used more than one time. The following 4 products show you different possibilities for longer lifetime and/or better pouring



Figure 1. Wellblock L0 installed in the ladle bottom

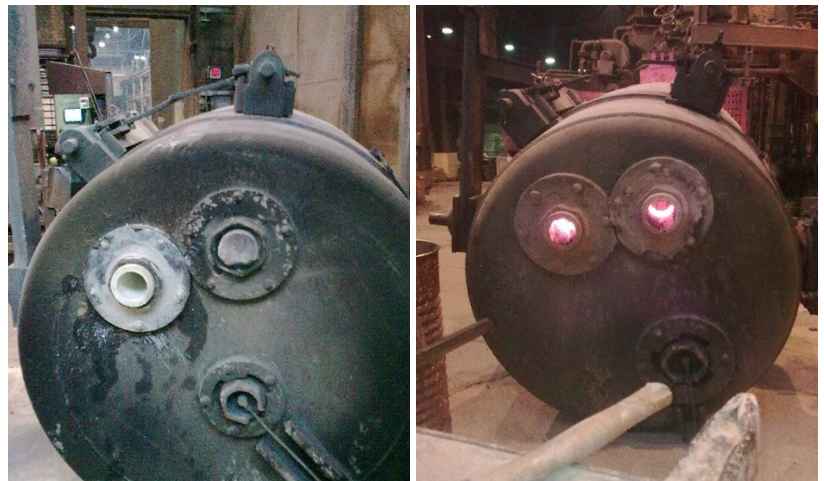

Figure 2: Typical one shot nozzle before use and after

ZONED NOZZLES

Normally a steel foundry nozzle is a One-Shot product. As the market demands improvements, the new ZONED-NOZZLE (Figure 3) for multiple usage has been invented.



Figure 3. Zoned nozzle

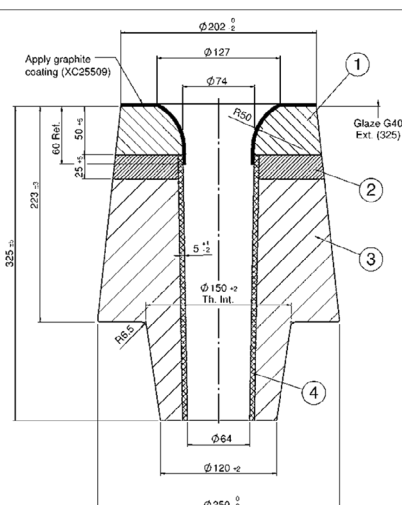

FEATURES OF ZONED NOZZLES:

1. High quality refractory material at the top for improved erosion resistance
2. Transition layer to reduce thermal expansion
3. A main layer with good thermal shock resistance
4. Inner layer for insulation purposes

The nozzle also has a non-stick coating around the closing area.

CROSS-BORE NOZZLES

Invented nearly 12 years ago, the cross-bore nozzle technology has replaced the cheap standard one shot nozzle in many steel foundries giving the benefit of a compact and controlled pouring stream and double lifetime.

This is important in case of high speed pouring with large nozzle diameters, but even for small diameters, the cross-bore nozzle could be a benefit when the pouring cup is small and the operator wants to achieve maximum control of the casting process.

Fig. 4. Cross-bore nozzle installed



Fig 5. Cross-bore nozzle sectioned after 2 ladle journeys, showing minimum wear of the body material



VAPEX FOSFLOW NOZZLE TECHNOLOGY

FOSECO VAPEX FosFlow (Figure 4) is a new system that allows for changes in nozzle diameter, even in a full ladle. VAPEX FosFlow alumina graphite nozzles use both carbon and ceramic bond technology. The combination of the two bonding systems provide unique beneficial properties for steel foundry ladle applications.

The system contains a BASE NOZZLE which remains in the refractory bottom of the ladle and an interchangeable POURING NOZZLE with possible different inner diameters. This POURING NOZZLE can be replaced quickly even within a ladle cycle.

FOSECO provides 6 different VAPEX FOSFLOW series > 40 (mainly for iron autopour runners) 45, 65, 65 extended, 100 and 100 extended for large ladles. The VAPEX FOSFLOW nozzle should be used in conjunction with VISO monobloc stopper technology that also allows multiple uses of the stopper (Figure 6 & 7).

Figure 6. Bottom Pour Ladle with VAPEX FosFlow



Figure 7. Base and Pouring Nozzles

BENEFITS

- Suitable for multiple use, mainly in steel foundry applications
- Pouring nozzle can be changed quickly
- Multi-use of the stopper & nozzle system resulting in labor cost reduction
- No cooldown of the ladle (energy savings, ladle lining performance)

As previously mentioned, VAPEX FosFlow can also be used in Iron Autopour applications. Here, the system offers a quick change of the pouring nozzle in the runner without losing time doing excessive refractory work. Especially on high speed molding such as DISAmatic, this system can be useful to minimise production downtime.

It is recommended to have spare runners to ensure an even easier and smoother change of the pouring nozzle in the maintenance area but for sure, the pouring nozzle can be changed easily on side and will be a quick help if the bore is blocked and a fast nozzle change within minutes is requested.

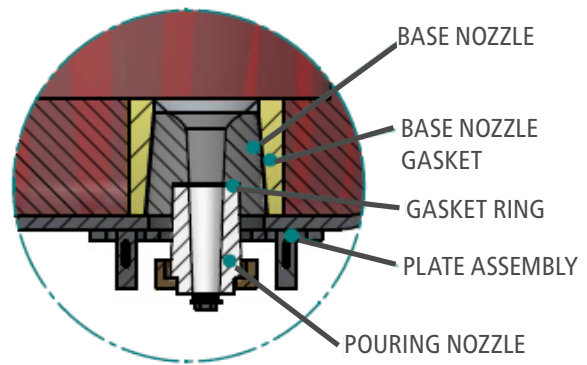

Figure 8. Installation Principle



Figure 9. VAPEX FosFlow system installed and ready to use



Figure 9. Conventional Nozzle in a runner of an Autopour Furnace, installed from the top

VESUVIUS ZIRCONIA NOZZLE OFFERINGS

Additive manufacturing is a future production technology to create complex shapes by using 3D printing technology. For this product range, high purity metal powders are requested.

Those metal powders need to match pure quality properties to gain best production results and they are mostly produced under vacuum melting and then atomized to get a final powder structure with optimized grain size.

As a consequence of that, different furnace producers are offering different technologies to reach the best metal qualities. After the melting, the pouring stream should be as small as possible so small zirconia nozzle with diameters having 8-14 mm as inner bore are state of the art here. Furthermore, Zirconia nozzles will give you the best properties in terms of thermal stability.

VESUVIUS have invested in a fully automated production for Zirconia nozzles for steel casting applications in their flagship plant in Skawina (Poland). We also offer turnkey refractory solutions, starting in the master melting shop where we supply dry vibratory linings for the Coreless Induction Furnaces.

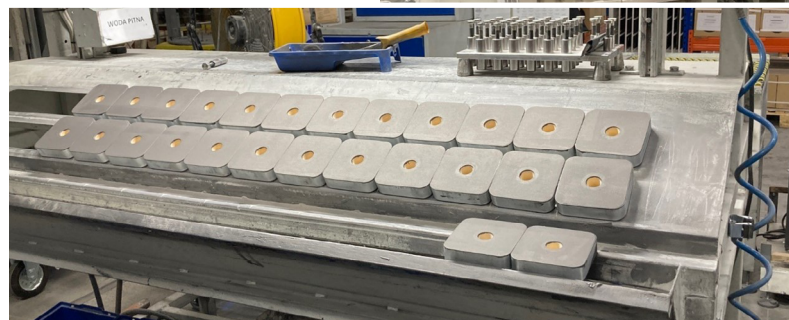

Those melting/casting machines are individual produced matching the customer demands. The picture below shows a scenario with pour cup, outer crucible and zirconia nozzle. FOSECO can supply this full set.

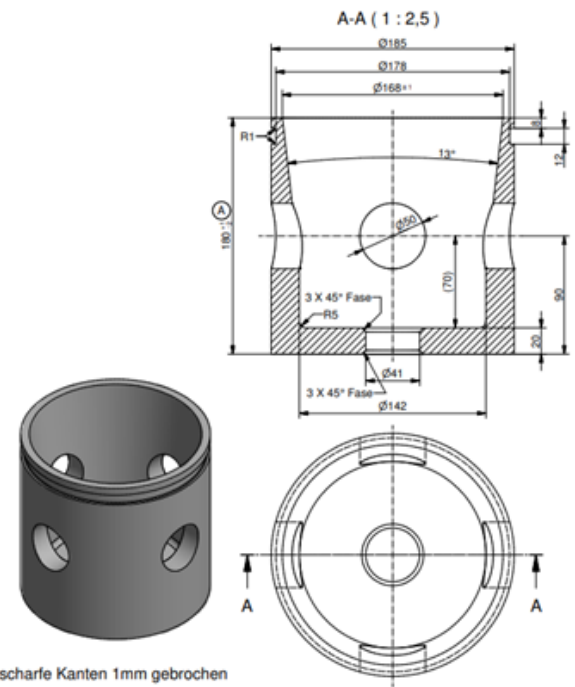
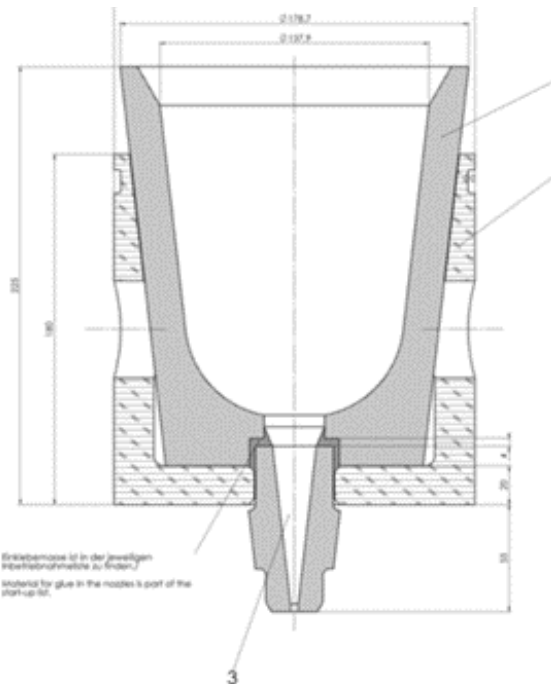

scharfe Kanten 1mm gebrochen

This drawing is the property of VESUVIUS and contains confidential and proprietary information. Any copying, use or disclosure of this drawing, or the information therein, without the written permission of VESUVIUS is strictly forbidden.

Temp. No.	DIMENSIONS (mm without tolerances)	DO NOT SCALE	SCALE 1:2.5	VOLUME (cm ³) (3 L)	WEIGHT 1.8dm ³ ☉										
File name	±1,5mm		TS 2902 IS 223												
ZYL31785200-A.lpt															
REVISION	Date	Name	 Stütztiegel, H=180 HD.ZYL31785200												
1	11.07.2008	Schäfer													
2	28.06.2017	Becker	<table border="1"> <tr> <td colspan="2">A</td> <td colspan="2">Toleranzen hinsichtlich</td> <td>28.08.2017</td> <td>A.K.</td> </tr> <tr> <td>Material</td> <td>Changes</td> <td>Date</td> <td>Name</td> <td></td> <td></td> </tr> </table>	A		Toleranzen hinsichtlich		28.08.2017	A.K.	Material	Changes	Date	Name		
A		Toleranzen hinsichtlich		28.08.2017	A.K.										
Material	Changes	Date	Name												
			Replacement for:	Replaced by:											

THE FUTURE

Looking at continuous improvements in pouring technologies, time and safety will become more important in the future. The VAPEX FosFlow nozzle system will be the best solution to allow a fast and safe change of the pouring nozzle in steel bottom pour ladles as well as autopoising systems for mass iron foundries. FOSECO can also offer a full range of products serving the rapid growth in production of metal powders for 3D printing of complex shapes.

CONCLUSION

Over the last decades, the production of nozzles for bottom pouring processes have evolved simple chamotte products to a highly technical, pure material product that allow better lifetimes and high tech products that satisfy demands that did not exist 5 years ago. With a significant investment to create a fully automated Zirconia nozzle production line, VESUVIUS will play an important role in this market in the future.

ABOUT THE AUTHOR

Rudi Bittniok is an International Marketing Manager for Flow Control Foundry. With 34 years of experience in the foundry industry and 26 years with the company, Rudi provides technical and commercial support to local teams worldwide in implementing Flow Control products into Iron and Steel Foundries. He enjoys the diversity of the products and applications in each foundry and values the learning experience every time he visits a customer. Additionally, Rudi appreciates the internal foundry network. In his free time, Rudi enjoys spending time with his family, listening to vinyl records, going to concerts, playing table tennis twice a week, and jogging and walking when time allows.

GET IN TOUCH WITH RUDI



click on the icon to get to his profile



rudi.bittniok@vesuvius.com



RUDI BITTNIOK
International Marketing Manager
Flow Control

All rights reserved. No part of this publication may be reproduced, stored in a retrieval system of any nature or transmitted in any form or by any means, including photocopying and recording, without the written permission of the copyright holder.

All statements, information and data contained herein are published as a guide and although believed to be accurate and reliable (having regard to the manufacturer's practical experience) neither the manufacturer, licensor, seller nor publisher represents or warrants, expressly or impliedly:

- (1) their accuracy/reliability
- (2) that the use of the product(s) will not infringe third party rights
- (3) that no further safety measures are required to meet local legislation

The seller is not authorised to make representations nor contract on behalf of the manufacturer/licensor.

All sales by the manufacturer/seller are based on their respective conditions of sale available on request.

*Foseco, the logo, VISO, VAPEX are Trade Marks of the Vesuvius Group, unregistered or registered in certain countries, used under licence.

©Foseco International Ltd. 2023

COMMENT

Editorial policy is to highlight the latest Foseco products and technical developments. However, because of their newness, some developments may not be immediately available in your area.

Your local Foseco company or agent will be pleased to advise.

VESUVIUS
A VESUVIUS GROUP COMPANY

